

Corina

VitrA®



Description	: Corina Elongated Bowl - Extended Height - ADA Compliant
Model Number	: 5232-XXX-0075
Compatible item	: 5070-XXX-5182 Tank with white plastic trim lever on left hand side - fluidmaster fill valve 5070-XXX-5183 Tank with chrome plated trim lever on left hand side - fluidmaster fill valve 5070-XXX-5184 Tank with copper plated trim lever on left hand side - fluidmaster fill valve 36-XXX-002 Toilet seat elongated 44-XXX-009 Toilet seat elongated (soft close hinges)
Water Consumption	: 1.6 GPF
Water Surface	: 8 1/4" x 8 7/8"
Water Depth From Rim	: 6 3/4"
Rough-In	: 12"
Minimum Water Pressure	: 20 psi.
Trap Diameter	: 2" ball pass with 2 1/8" trap diameter
Trap Seal Depth	: 2 3/8"
Shipping Weight	: 5232: 53 lbs. 5070: 38 lbs.
Shipping Dimensions	: 5232: 14 1/2" W X 28 1/2" L X 18 1/8" H 5070: 10 1/4" W X 20 1/2" L X 18 1/8" H 15 1/8" W x 28 3/4" L x 18 7/8" H
Installation Guide	: VitrA Guide 312851
Material	: Vitreous china
Colors	: 003 White 017 Bone, 068 Biscuit (Basic Colors) 001 Edelweiss, 070 Black (Special Colors) "XXX" indicates the color
Included components	: Tank fittings, bolt caps (white 310359 / bone-biscuit 310306)
Standards	: Meets the American Disabilities Act Guidelines and ICC/ANSI A117-1 requirements when installed so top of seat is 17" from the finished floor. Recommended seat for ADA requirements: VitrA 36-003-002 ASME A 112.19.2, CSA B45, ADA ICC/ANSI A117-1, LADWP/SPS (City of Los Angeles)
Warranty	: 10 year limited warranty

1

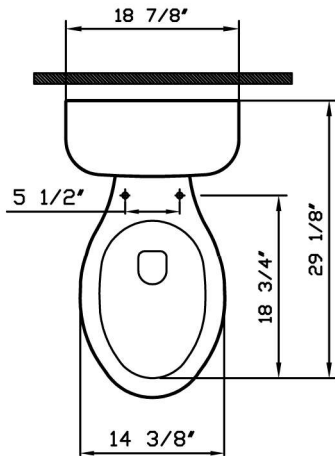

2

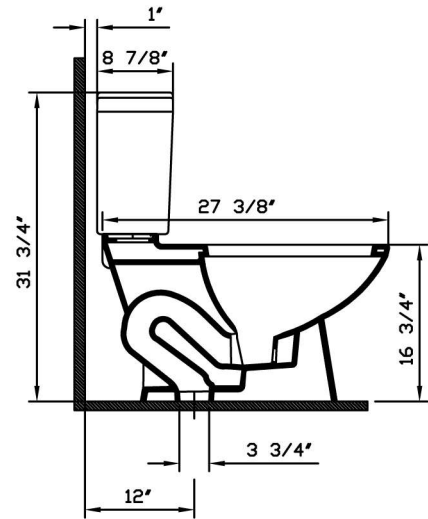

3

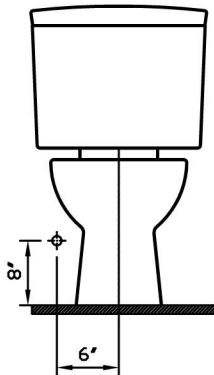

Notes:

- DIMENSIONS SHOWN FOR THE LOCATION OF THE SUPPLY IS SUGGESTED.
- INSTALLATION INSTRUCTIONS SUPPLIED WITH THE TOILET.

IMPORTANT: Dimensions of fixtures are nominal and may vary within the range of tolerances established by ASME Standard A 112.19.2, CSA Standard B45. These measurements may be subject to change. No responsibility is assumed for the use of superseded or voided pages.

August, 2006