

# Commercial Line

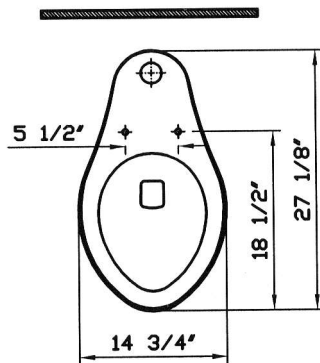

Description	: Flushometer Toilet Elongated Bowl,
Model Numbers	: 6521-XXX-0075 6521-XXX-0598 (with bed pan lugs)
Water Consumption	: 1.6 GPF
Water Surface	: 14 3/4" x 12 1/8"
Water Depth From Rim	: 4 3/8"
Rough-In	: 10" or 12"
Minimum Water Pressure	: 20 psi.
Trap Diameter	: Fully glazed 2" ball pass trapway with 2 1/8" diameter
Trap Seal Depth	: 2 3/8"
Shipping Weight	: 47 lbs.
Shipping Dimensions	: 15 1/8"W x 29 1/8"L x 18 5/8"H
Included Components	: Spud (313209) Bolt caps (white 310359 / bone-biscuit 310306)
Material	: Vitreous china
Colors	: 003 White 017 Bone, 068 Biscuit (Basic Colors) "XXX" indicates the color
Standards	: ASME A 112.19.2, CSA B45, CMR 248 (State of Massachusetts)
Warranty	: 10 year limited warranty

1



2

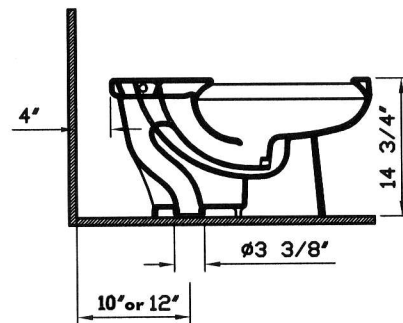

Notes:

- DIMENSIONS SHOWN FOR THE LOCATION OF THE SUPPLY IS SUGGESTED.
- INSTALLATION INSTRUCTIONS SUPPLIED WITH THE TOILET.

IMPORTANT: Dimensions of fixtures are nominal and may vary within the range of tolerances established by ASME Standard A 112.19.2, CSA Standard B45 and CMR Standard 248 (State of Massachusetts).

These measurements may be subject to change. No responsibility is assumed for the use of superseded or voided pages.

April, 2005